

08:220-1908

MICROBOOSTER HEAT PUMP



Manual

METRO Microbooster P
METRO Microbooster PS
METRO Microbooster V
METRO Microbooster VS

TABLE OF CONTENTS

Introduction	4
1. About the product	4
2. Transport, Handling and Delivery	13
3. Positioning	15
4. Water Circuit	17
5. Electric Connections	22
6. Optimal operation	23
7. Control and Operation	25
8. Maintenance	41
9. Disassembly & Decommissioning	43
10. Troubleshooting	44
11. Warranty	46
12. Declaration of conformity	48
13. Product and installer information	49

INTRODUCTION

The aim of this manual is to give information, instructions and warnings on the Microbooster Domestic Hot Water Heat Pump (MBHP). The manual is to be used by installers and plumbers as well as by end users, since it contains important safety information. The manual is a part of the Microbooster heat pump and it is to be conserved with care, since it contains important installation and maintenance instructions that can be useful to assure a long lifetime and an efficient operation.

1. ABOUT THE PRODUCT

The product is a Microbooster heat pump that has been designed according to EU directives. The product is intended for hot water production for domestic use or for similar applications. The unit has been designed to be ready for installation.

1.1. Safety precautions

- The product must be installed, commissioned, and repaired only by qualified technicians. Incorrect installation can result in damages of properties and personal injuries.
- The unit must be disconnected from the power supply when the cover is off.
- The unit must not be used by children or by people with limited physical or mental capacity.
- Children should be supervised to ensure that they do not play with the appliance.
- Cleaning and maintenance must not be done by children without supervision.
- Do not place flammable materials in contact or close to the unit.
- The water system should be installed as stated in the manual.
- When in service, the unit should not be placed in subzero temperature areas.
- When not in service, the unit can be placed in subzero temperature areas, but all the water in the tank or in the condensate drain must be removed beforehand.
- Hot water can cause serious burns if directly connected to the taps. The installation of a mixing valve is suggested.
- The unit should be used only for its specified purpose. The manufacturer is not liable for any damages due to failure to observe this manual.
- Take all the possible precautions to avoid incidents.
- The product contains HFC-R134a.

1.2. Technical data

1.2.1. General

The unit is composed of a water tank, a refrigerant circuit, a cabinet and a display that is connected to a control board. The main scope of the appliance is to heat water stored in a tank.

1.2.2. Operation

The unit is programmed to start heating the water inside the tank when its temperature falls below a predetermined level. The unit stops when the water temperature reaches a set point that can be regulated by the user. In general, the appliance is designed to produce enough hot water to cover the need of a household of 4 persons or more.

There are two main ways in which the unit can heat the water. These are determined by the temperature of the heat source upon entry:

1) Internal coil operation (Heat source temperature > Domestic hot water temperature)

This mode of operation only applies to models with internal coil. If the heat source has a temperature above the domestic hot water temperature upon entry, it can be used to pre-heat the water in the tank. This is done by directing the heat source through an internal coil in the water tank, thereby transferring heat from the heat source to the domestic water. The cooled heat source is then sent through the refrigerant cycle (as seen in paragraph 1.2.3). Using the heat source to pre-heat the domestic water boosts the efficiency of the heat pump.

2) Heat pump operation (Heat source temperature < Domestic hot water temperature)

When the heat source enters the unit at a temperature below the domestic hot water temperature, only the heat pump operation is used. In the operation with heat pump, a refrigerant cycle utilizes the operation of a compressor and a heat source at low temperature to heat the water in the tank to a higher temperature level.

1.2.3. Refrigerant circuit

As depicted in Figure 1 and 2, the heat pump cycle can be divided in four main processes: compression (1-2), condensation (2-3), expansion (3-4), evaporation (4-1) described below:

- At the suction of the compressor (1) the superheated refrigerant gas enters the compressor at low pressure.
- In the compressor, the refrigerant is compressed to a higher pressure and temperature level (2).
- The refrigerant is cooled and condensed in the condenser exchanging heat with the water stored in the tank.
- The refrigerant exits the condenser in a subcooled, liquid form (3)
- Through a thermostatic expansion valve the pressure of the refrigerant is lowered to allow its evaporation at lower temperatures (4).
- The refrigerant is evaporated in the flat plate heat exchanger that uses a liquid as heat source (1).
- The process goes on until the power supply to the compressor is stopped.

A deeper description of the refrigerant circuit and all components used for its design can be found in Figure 3, 4 and 5.

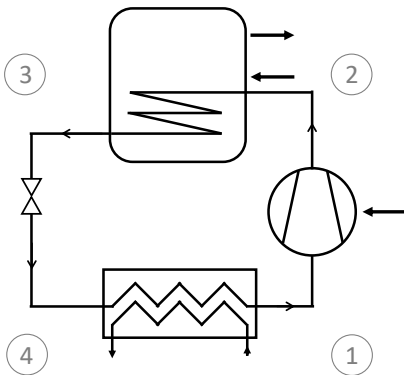

Figure 1 - Heat pump principle

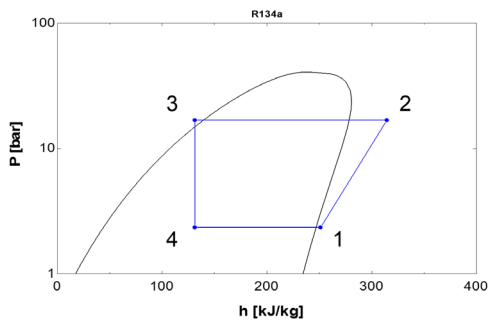

Figure 2 - Pressure-Enthalpy diagram

1.2.4. Safety instructions - Refrigerant circuit

- Only skilled and trained technicians shall carry out repair and service of the heat pump circuit.
- Before opening the refrigerant circuit, discharge the heat source to a level that allows safe working conditions.
- Special attention should be given if the maintenance of the unit is carried out with an open flame.

1.2.5. Process and Instrumentation Diagram

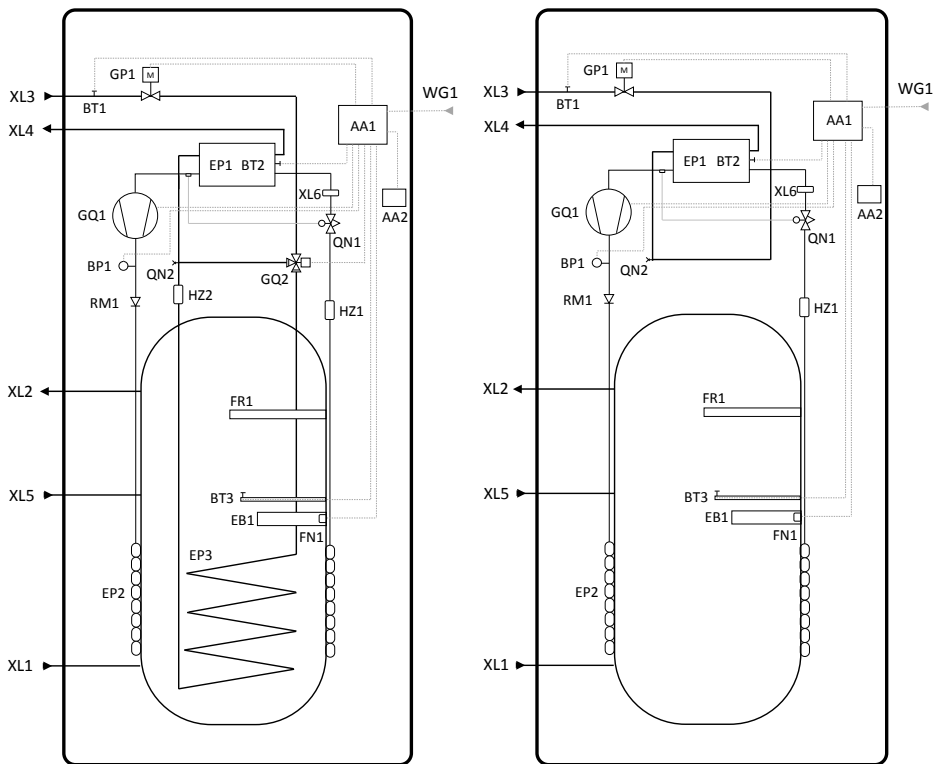

Figure 3 - Process and Instrumentation Diagram with coil (left) and without coil (right)

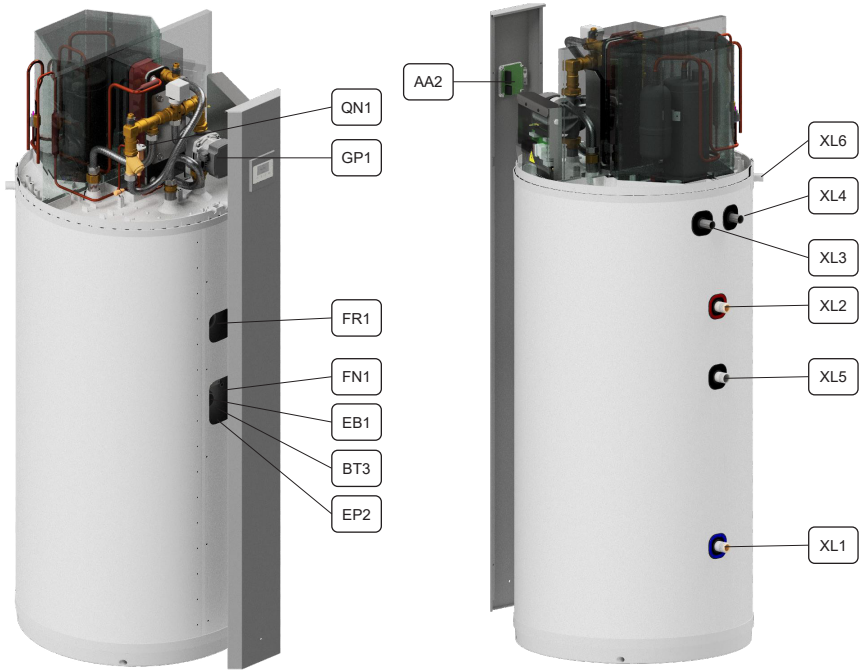

Figure 4 - Design of the refrigerant circuit and the main components

Refrigerant circuit

GQ1: Compressor
 RM1: Check valve
 EP1: Evaporator
 EP2: Condenser
 HZ1: Filter drier
 QN1: Thermostatic expansion valve
 XL7: Service valve

Water circuit

XL1: Water inlet
 XL2: Water outlet
 XL3: Heat source inlet
 XL4: Heat source outlet
 XL5: Water recirculation
 XL6: Condensate outlet
 EP3*: Coil
 EB1: Electric heater
 FR1: Anode
 GQ2*: Three-way valve
 QN2: Air vent
 HZ2*: Strainer
 FN1: Thermal protection

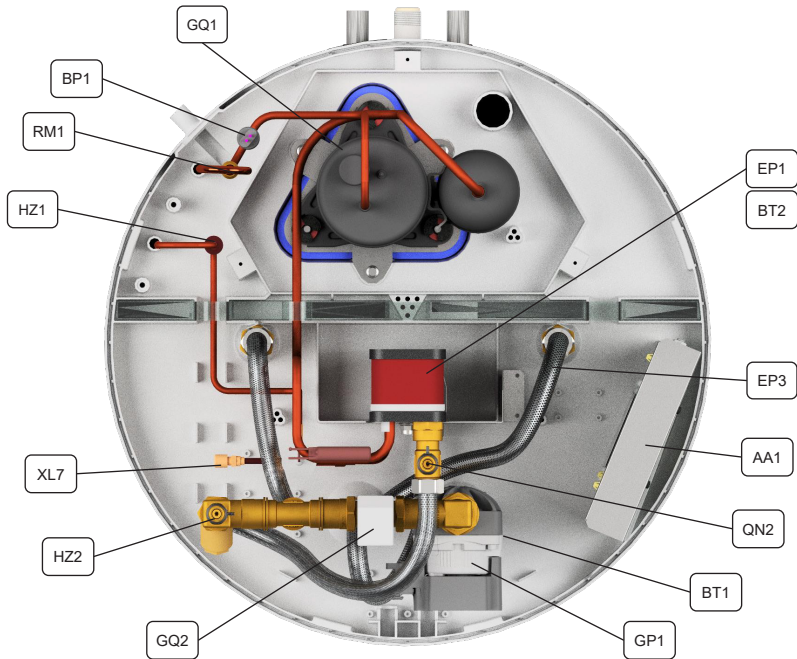

Figure 5 - Design of tank, condenser and related components

Sensors

- BT1: Heat source inlet temperature
- BT2: Heat source outlet temperature
- BT3: Tank water temperature
- BP1: High pressure switch

Electric components

- AA1: Main printed circuit board
- AA2: Display circuit board
- GC1: Solar (PV) 0-10V (fig. 13)
- QA1: SG-ready port (fig. 13)
- GP1: Pump OR flow control valve

The items with * are only found on models with internal coil.

Nomenclature according to standard IEC 81346-1 and 81346-2.

1.2.6. Main Technical Data

The main technical data are collected in the following figures and table.

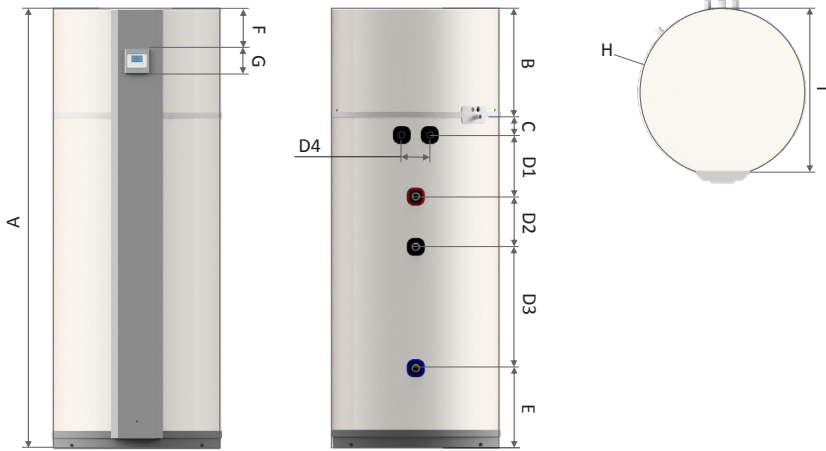

Figure 6 - Dimensional data

Parameter	Unit	P	V	PS	VS
Dimensional data					
A - Height	mm		1570		
B	mm		385		
C	mm		65		
D1	mm		220		
D2	mm		180		
D3	mm		435		
D4	mm		100		
E1	mm		285		
F	mm		140		
G	mm		86		
H - Diameter	mm		Ø603		
I - Max diameter	mm		Ø620		
Height required for installation	mm		1730		
Weight dry	kg	98		104	
Nominal insulation thickness	mm		50		
Nominal volume, storage tank	l	190		180	

Parameter	Unit	P	S	PS	VS
Electrical data					
Power supply	V/Hz	230/50			
Fuse	A	13 (10)			
Electric connections	-	L1, N, G			
Electric heater power	W	1500			

Refrigerant and water circuit					
Refrigerant type	-	R134a			
Refrigerant quantity	g	1220			
GWP	-	1430			
CO2 equivalent	ton	1,7			
Refrigerant circuit	-	Hermetically sealed			
Protection rating	-	IP21			
Water connections - enamelled	in	¾ - BSPT (ISO 7-1)			
Water connections - stainless	mm	22 - Compression fittings			
Heat source connections	mm	22 - Compression fittings			
Heat source temperature range	°C	5 (10*) - 55		5 (10*) - 60	
Min. heat source flow	l/h	100			

Performance data					
Heat source at 25°C, domestic hot water at 10-53,5°C (EN16147, L)					
COP	-	5,3		5,2	
Heat up time	hh:mm	04:30			
Heating capacity	W	2100			
Stand-by heat losses	W	12			
Heat source at 40°C, domestic hot water at 10-53,5°C (EN16147, L)					
COP	-	6,0		8,5	
Heat up time	hh:mm	02:50		03:45	
Heating capacity	W	2700		2500	
Stand-by heat losses	W	9			
Volume at 40°C	L	247		234	
Sound power	dB(A)	46			

*If brine is used as heat source the minimum temperature is 5 °C.

If uninhibited water is used the minimum temperature is 10 °C.

Parameter	Unit	P	V	PS	VS
Operating limits					
Max. compressor power	W	600			
Max. water temperature (heat pump only)	°C	65			
Max. water temperature (heat pump and electric water heater)	°C	65			
Min. required heat source flow	l/h	100			
Max. domestic hot water pressure	MPa	1,0			
Max. allowed heat source pressure	MPa	0,3	1,0	0,3	1,0
Max. available pressure difference	kPa	20	600	20	600

All data are to be subjected to 3rd party test.

2. TRANSPORT, HANDLING AND DELIVERY

Immediately upon receipt, the domestic hot water heater pump must be examined to make sure that it is intact and undamaged. If not, the shipping company must be informed immediately. The recipient has the responsibility for all the shipments unless otherwise agreed.

2.1. Delivery Mode

The appliance is delivered without condensate drain tube and the safety equipment for the water circuit.

2.2. Storage

The unit must be stored and preferably transported upright, free of water and within its packaging.

Transport and storage may take place at temperatures between -10 °C and +50 °C. If the unit has been transported or stored at sub-zero temperatures the unit should be left at room temperatures for 24 hours before commissioning.

2.3. Transport with Forklift

For transport with a forklift, the unit must stand on the associated transport frame. Always lift the unit slowly. Due to the high center of gravity, the appliance must be secured against tipping during transportation.

2.4. Unloading the Heat Pump

In order to avoid damages, the unit must be unloaded on a flat surface.

2.5. Transport with Trailer

The unit must only be transported on the associated transport frame. This also applies to transport on stairs (figure 7).

The unit must be secured against sliding on the trailer.

Water connections etc. shall not be used for transportation purposes.

It should be made sure that the trailer does not damage the cabinet or the various connections.

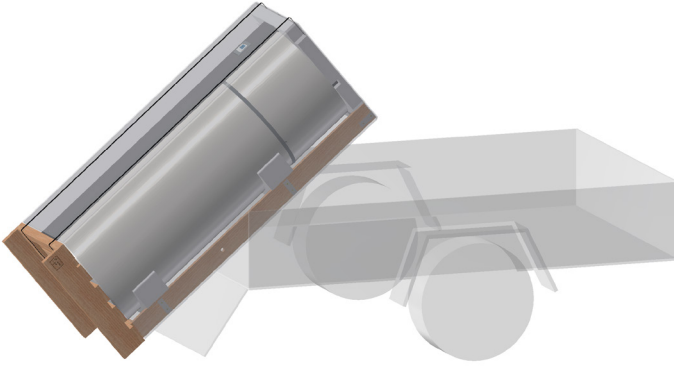

Figure 7 - Transport with trailer

2.6 Horizontal transport

When carefully transporting the unit over a short distance to its final location, the unit can be transported horizontally in its packaging on the dedicated side. If the unit has been tilted more than 45°, the unit must be left in its normal upright position for at least 24 hours before it is started.

3. POSITIONING

The installation site should be equipped with a power supply of 220-240V and 50 Hz. The power supply and the hydraulic system must comply with the local regulations.

The unit should be placed vertically, with a maximum inclination of 1°. The unit must be well balanced and stable on the ground surface. Use the built-in adjustable pads to level the unit.

The unit must be installed as close as possible to the hydraulic system in order to minimize heat losses in the water pipes. The water pipe outlet should be insulated for the same reason.

The unit should not be placed in direct contact with the sunlight.

The unit can only be installed in a frost-free room and it should follow the criteria:

- Room temperature between 5°C and 35°C.
- Drain possibility for condensate and floor drain.
- Solid base (approx. 500 kg / m²).
- It is necessary to ensure that there is sufficient space around the unit for maintenance and service. A clearance of 0,5 m around the unit is recommended.

Once the appliance is located in the right position, remove the packaging and remove the unit from the pallet.

3.1. Set-up sequence

Once the unit is placed in a room with characteristics as specified in the previous paragraph, then it can be prepared following the sequence described below:

1. Remove the packaging from the pallet.
2. Remove the transport fittings from the pallet.
3. Remove the unit off the pallet and place it on the floor.
4. Adjust the unit vertically by adjusting the feet.
5. Check that the unit has no damages.
6. Set up the water circuit (See chapter 4) and fill the tank with water.
7. Set up the electric connections (See chapter 6).

When the unit is supplied with electricity, it automatically starts running in its standard operation according to the factory settings as described in Chapter 7.

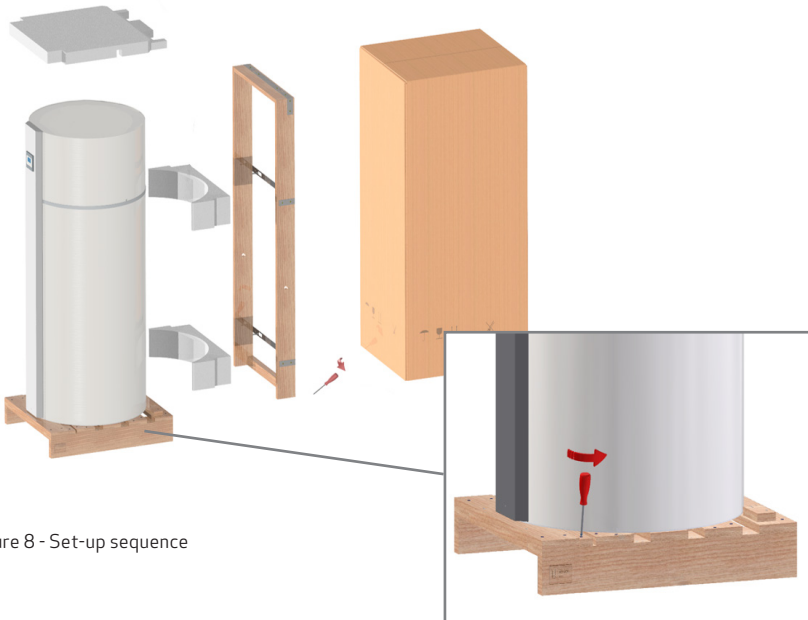

Figure 8 - Set-up sequence

4. INSTALLATION OF WATER CIRCUIT

The water circuit must be installed in accordance with local norms and standards. The water used in the hot water- and heat source systems must fulfill the following requirements:

- **The domestic hot water circuit and tank** must only contain drinking water.
- **The heat source circuit** can contain almost any low temperature water source (brine, district heating, space heating return or ground source heat pump).

Material compatibility in the whole system must be ensured. Incorrect material combinations in the water circuit can lead to corrosion damage due to galvanic corrosion. This requires special attention when using galvanized components and components that contain copper. The pipe sizes for on-site installation shall be based on the available water pressure as well as the expected pressure loss in the pipe system. As for all pressurized vessels, the heat pump water tank has to have an approved safety valve (pressure setting depending on local rules and regulations) and a non return/check valve on the cold water inlet. An external filter HZ3 should be installed before cold water inlet XL3.

Figure 9 depicts the suggested configuration on the water system.

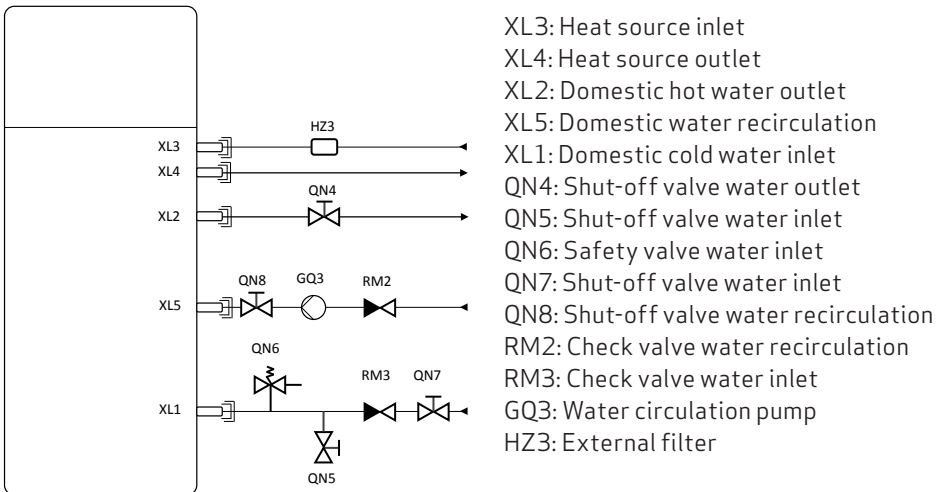

Figure 9 - Diagram of suggested water circuit connections

4.1. Domestic water connections

Dirt in the pipe work must be avoided. After installation of the external pipes flush if required before connection of the domestic hot water heat pump.

If no circulation of water is needed, **make sure that the circulation connection is properly sealed.**

When installing the pipes please ensure that the pipe connections are not excessively stressed. Use a pipe wrench to relax torque forces on the pipe connections.

The water pipe outlet should be insulated to reduce heat losses to the ambient and to reduce the risk of injuries and burns.

4.2. Location of connecting pipes

Be sure to discern between **domestic water** and **heat source** when connecting the water pipes:

- Heat source inlet is mounted on the 1st connecting branch (XL3).
- Heat source outlet is mounted on the 2nd connecting branch (XL4).
- Domestic hot water outlet pipe is mounted on the 3rd connecting branch (XL1).
- Domestic hot water recirculation pipe is mounted on the 4th connecting branch (XL7).
- Domestic cold water inlet is mounted on the 5th connecting branch at the bottom (XL2).

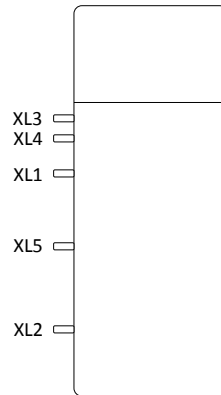

Figure 10 – Location of connecting pipes.

4.4. Safety instructions - Water circuit

- Only drinking water must be used in the domestic water circuit.
- During installation, attention must be paid to the choice of materials and it must be ensured that chosen materials work together without problems in the entire circuit.
- Special attention must be paid when using galvanized components and components containing aluminum.
- Safety equipment must be installed to prevent over pressure in the system. Always use a safety valve with maximum relief pressure according to the unit nameplate and a stop valve (approved according to heating and plumbing regulations). All pipe work has to be installed according to plumbing and heating regulations.
- The discharge pipe of the pressure-relief device (safety valve) must be installed frost free and with a slope away from the device. The pipe must also be left open to the atmosphere.
- Temperatures above 89 °C in the heating coil may cause excessive pressures in the refrigerant circuit.

4.5. Leak test

After installation it is necessary to check that the entire water installation is tight. This is accomplished by performing a water leak test.

4.6. Commissioning of the domestic water circuit

IMPORTANT!

Before commissioning the water circuit please read chapter 6 "Optimal Operation".



Fill the water tank via the cold water connecting branch. Disconnect the front panel and deaerate the water tank by opening one of the hot water taps located at the highest level until air no longer appears at the tapping point.

A few days after the initial setup and start-up, check the installation for leaks in the water installation.

5. ELECTRIC CONNECTIONS

The unit must be supplied with current at 220-240V and 50 Hz.

The unit is supplied with a standard Schuko plug. If local regulations dictates fixed installation or if the supplied plug does not ensure correct earthing, cut off the Schuko plug from the power supply cable.

If the unit is supplied with a pump this will be connected to GQ2 and GP1.
 If the unit is supplied with a valve this will be connected to QN1 and GP1 (L).

When the unit is connected to the power supply, it will turn on automatically and it will start its operation automatically.

- The first time that the unit is turned on, it will starts its operation according to its factory settings.
- If some control settings are modified, the unit will starts with the same settings at the previous switch off conditions.

5.1. Electric Diagram

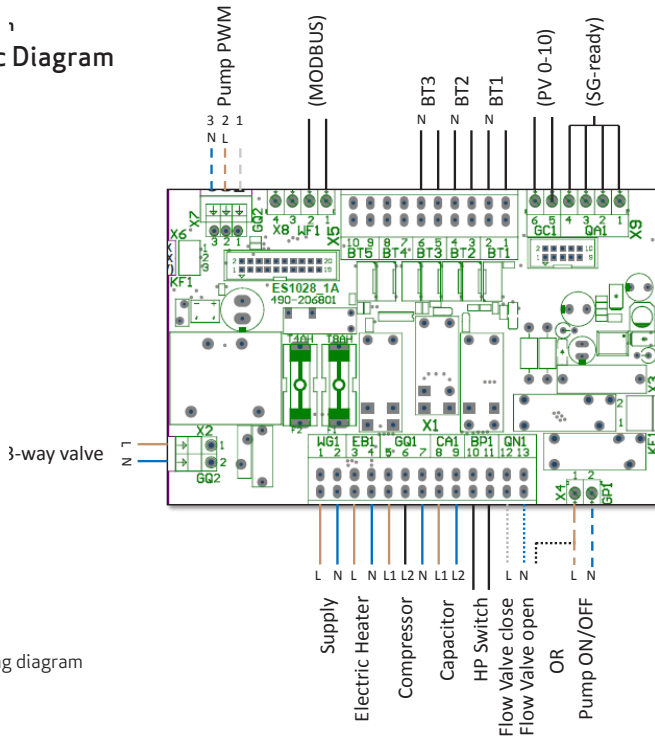

Figure 13 - Wiring diagram

6. OPTIMAL OPERATION

Only when the unit is connected heat source supply and domestic water supply it is safe to connect the electrical circuit to a power supply. Once the heat pump is connected to the power supply it will start in AUTO mode. Follow the steps in paragraph 7.1 and 7.2 for optimal operation of the Microbooster Domestic Hot Water Heat Pump.

IMPORTANT!

The Microbooster Domestic Hot Water Heat Pump must **ONLY** be started with a filled water tank and heat source circuit!



6.1. Step one: Check for air in the heat exchanger

The unit will not operate optimally with air in the heat source system. In order to assure that no air is trapped in the evaporator, open air vent (QN2) shown in Figure 14, until only water drops out. Place a container underneath to capture drain water. Close the valve once any air is fully drained.

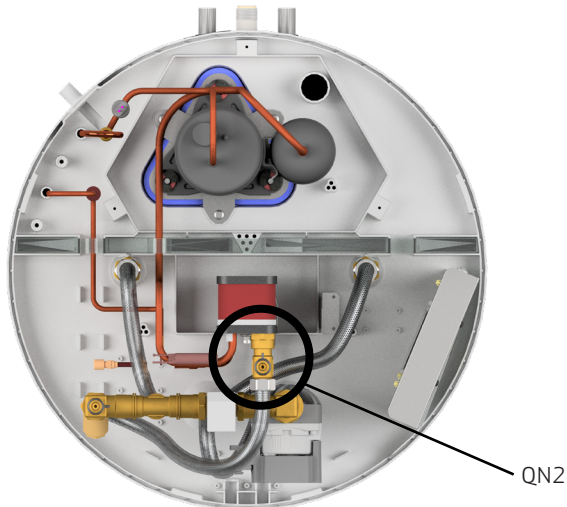

Figure 14 - Location of air vent (marked with ring).

6.2. Step two: Control operating water flow

Once the unit is running in AUTO mode it is important to control whether the water flow is sufficient. After approximately 10 minutes of operation “E7” will occur if the water flow is insufficient.

If “E7” occurs, increase the minimum source flow (D4) with +10.

After adjusting the parameter, monitor the operation for another ten minutes. If “E7” occurs again, repeat step 1 until the unit operates with no error.

6.3. Pump operation

If the unit is equipped with a pump, additionally implications must be considered, since the water flow is dependent on the pressure drops in the heat source system. Figure 15 describes the relationship between pump head pressure and water flow.

A minimum flow of 100 l/h should be assured.

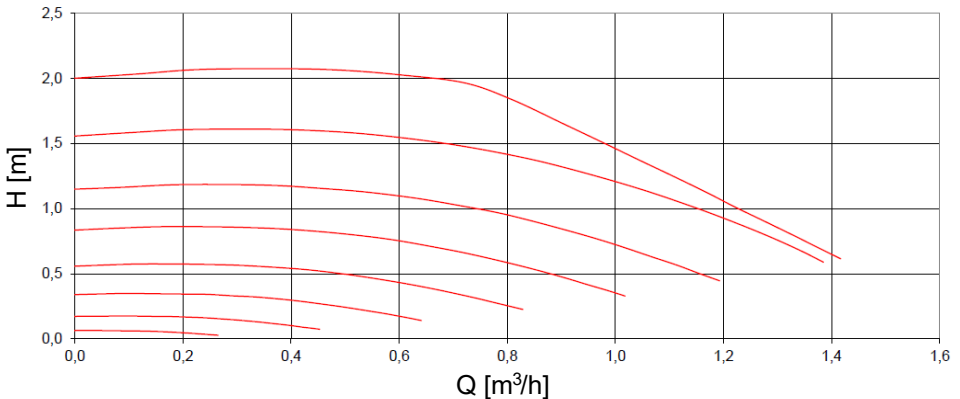

Figure 15 - An illustration of the relationship between pump head pressure and water flow.

7. CONTROL AND OPERATION

7.1. Home view

The unit can be controlled from the control panel described in Figure 16. From the home view, all the main operational modes, functions, set points and information on the unit can be accessed.

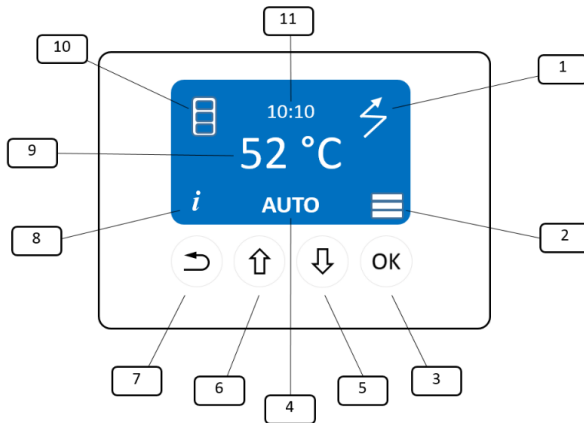

Figure 16 - Display, control panel

- 1: Electric heating state (ON/OFF)
- 2: Main menu (Can be open by pressing **OK**)
- 3: OK/Enter
- 4: Mode (Change with ↓ or ↑)
- 5: Scroll down
- 6: Scroll up
- 7: Return back
- 8: Information (open with ↶)
- 9: Temperature set point
- 10: Heat pump operation
- 11: Time

The top part of the screen gives information about the unit operation, time and temperature set point. This part is passive and it is changed automatically.

The bottom part of the screen is active, meaning that the icon on the screen contains other menu items. This part is divided in three menus:

- INFORMATION MENU (8), that can be accessed by pressing (↩)
- MODE MENU (4), that can be accessed by pressing (↓) or (↑)
- MAIN MENU (2), that can be accessed by pressing (OK)

The MAIN MENU is composed of 4 sub menus:

- Temperatures
- Functions
- General
- Installer

The menu items with * are optional functions.

7.2. Information menu

The information menu can be opened pressing button (↩) from the home view. This menu gives all the operational information of the unit. The available information are divided in four groups:

- Temperatures (T)
- Collected data on the unit operation and performance (I)
- The state of the relays of the unit (R)
- The errors and alarms of the unit (Er)

All the information that can be shown in the information menu are described in the following table. All temperatures are in °C.

Class	Code	Menu Item	Description
T	T1	T s i	The heat source inlet temperature.
	T2	T s o	The heat source outlet temperature (evaporator temp.).
	T3	T tank	The domestic hot water temperature in the storage tank.
V	V1	Flow %	The actual flow of the heat source in percentage.
	V2	Input V*	The actual input signal in GC1 (0-10V) from the PV in Volts.
I	I1	HP hr	The amount of hours that the compressor has been running.
	I2	EL hr	The amount of hours that the electric heater has been running.
	I3	Flow hr	The amount of hours that the flow control valve or the pump has been running.
	I4	Tsi a	The average inlet heat source temperature with operating unit is displayed in C.
	I5	Tso e	The average outlet heat source temperature (evaporator temperature) with operating unit is displayed in C.
	I6	HP ON	The number of START/STOPS for the entire unit life time since last Reset All.
	I7	W el	The calculated instantaneous electricity consumption in W since last Reset All.
	I8	MWh el	The total calculated electricity consumption in MWh since last Reset All.
	I9	W th	The calculated instantaneous heating capacity is displayed in W.
	I10	MWh th	The total calculated hot water production is displayed in MWh since last Reset All.
	I11	EL MWh	The electricity consumption of the electric resistance in MWh since last Reset All.
R	R1	Flow ON	The status of the relay used for the control of the heat source flow is shown. For units equipped with a pump, this relay activates the built-in pump. For units with a control valve, this relay increases the heat source flow.
	R2	Flow OFF	The status of the relay that controls the solenoid valve for the defrosting function is shown.
	R3	Coil	The status of the operation of the coil is shown.
	R4	HP	The operation of the compressor is shown.
	R5	EL	The electric heater operation is shown.

Class	Code	Menu Item	Description
Er	E1	T1 Error	The temperature sensor T1 is out of range. If this error occurs, the unit does not heat the water in any way.
	E2	T2 Error	The temperature sensor T2 is out of range. If this error occurs, the unit does not heat the water in any way.
	E3	T3 Error	The temperature sensor T3 is out of range. If this error occurs, the unit does not heat the water in any way.
	E6	HP	The high-pressure switch interrupts the unit operation when the pressure in the refrigerant circuit is above the specified maximum pressure.
	E7	C Evap	Cold evaporator. The temperature T2 is below D11 (Evaporator T min).
	E8	H Evap	The temperature T1 is above D10 (Evaporator T max).
	E9	No cap	This error stops the unit operation if heating capacity is below nominal conditions.
	E10	H T s i	The heat source inlet temperature T1 is higher than D8 (Source T max).
	E11	Service	The unit requires periodical maintainance.

7.3. Mode of operation

Different strategies to heat the water can be selected from the main control panel pressing 5 or 6 (Scroll down or scroll up) from the home view (figure 17).

The possible modes of operation to choose from are found in the following table:

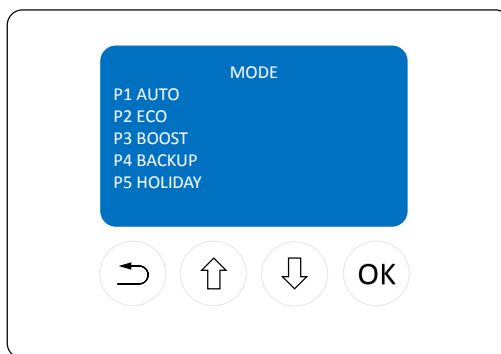

Figure 17 - Modes of operation

Code	Set point name	Description
P1	AUTO	The heat pump heats the water when required using the heat pump operation. Under normal conditions, the compressor works until A1 T AUTO set point is reached. If the source temperature is below D7 Source T min, the electric heater starts and the heat pump shuts-off. Hysteresis can be changed in the installer menu D35 (Water hysteresis).
P2	ECO	The heat pump consumes as little energy as possible. The heat pump operates at a lower water temperature set point A2 (T ECO). Hysteresis can be changed in the installer menu D35 (Water hysteresis).
P3	BOOST	The heat pump and the electrical heater operate simultaneously when possible (interim mode is forced from the beginning of the heat up cycle). If D28 (T HP max) is greater than A3 (T BOOST) the compressor stops at the temperature setpoint D28 (T HP max), otherwise the compressor stops at A3 (T BOOST).
P4	BACKUP	This is an emergency mode. In BACKUP mode the water is heated up by the electric heater at a lower temperature than the desired one. The Legionella control is active in any case.
P5	HOLIDAY	The heat pump is turned off and only the LCD display is active. The heat pump does not start when water heating is required. The compressor is OFF except during LEGIONELLA control in which it can be activated. The HOLIDAY mode is connected to B3 (Hot on time) function. After the B3 (Hot on time) timer is over, the unit goes back to the previous mode of operation.

Note: the unit can be turned off switching to HOLIDAY mode.

7.4. Main Menu

Entering this menu requires a good understanding of the unit operation. It is highly recommended to read and understand the descriptions of the following menu items. Changing some of these set points can have large effects on how the appliance operate and performs.

The main menu is divided in four sections:

- A - Temperatures
- B - Functions
- C - General
- D - Installer

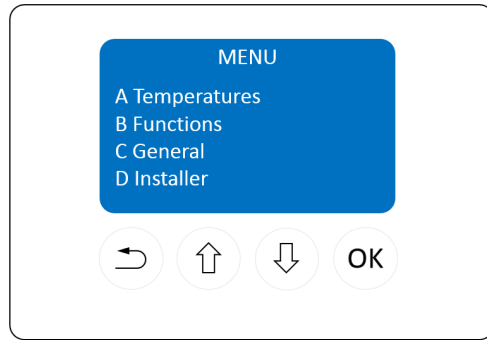

Figure 18 - Main menu

7.4.1. Temperatures

The temperature set points can be changed under the menu point “temperatures”. Different temperature set points can be adjusted according to the relative mode of operation. All temperatures are in °C.

Code	Set point name	Description	Range	Factory setting
A1	T AUTO	The temperature level at which the unit heats the water when the AUTO mode is selected. Hysteresis can be changed in the installer menu D35 (Water hysteresis).	5 - 65	53,5
A2	T ECO	The temperature level at which the unit heats the water when the ECO mode is selected. Hysteresis can be changed in the installer menu D35 (Water hysteresis).	5 - 55	50
A3	T BOOST	The temperature level at which the unit heats the water when the BOOST mode is selected. Hysteresis can be changed in the installer menu D35 (Water hysteresis).	5 - 65	53,5

7.4.2. Functions

The functions are similar to the modes of operation but they cannot be accessed directly from the home view and they can vary from unit to unit.

Code	Set point name	Description	Range	Factory setting
B1	Source flow control	AUTO	AUTO/ FIXED/ DELTA T	AUTO
		FIXED		
		DELTA T		

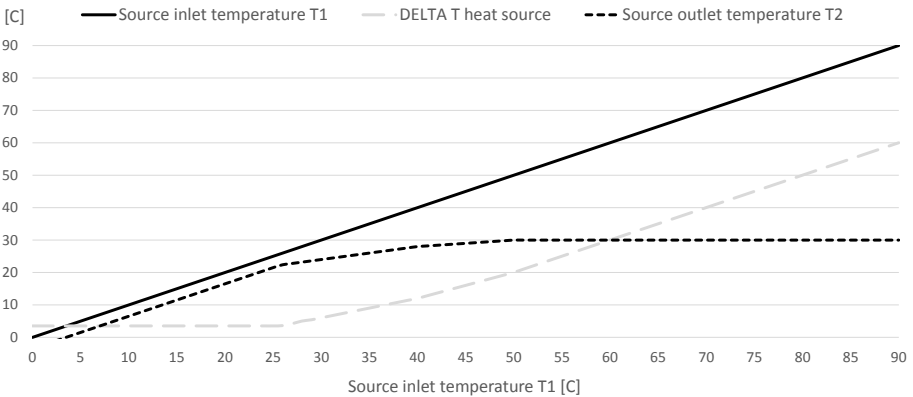

Figure 19 - The temperature difference between heat source inlet and outlet.

Code	Set point name	Description	Range	Factory setting
B2	Low tariff	Standard	OFF/ STANDARD/ OPTIMAL 1/ OPTIMAL 2	OFF
		Optimal 1		
		Optimal 2		
B3	Hot on time	The unit can be programmed to deliver hot water from 1 to 30 days from the moment in which the function is activated and the HOLIDAY mode is selected. The unit switches to AUTO MODE in the desired number of days.	OFF/ON	OFF
B4	Photovoltaic	OFF*	OFF/ ECO/ STORAGE	OFF
		PV ECO*		
		PV STORAGE*		

7.4.3. General

The general section collects all the standard settings that have little or no effect on the heat pump operation, except for the menu item Reset.

Activating the Reset function brings all the set points to the factory settings value.

The set points of the General menu are described in the table below.

Code	Set point name	Description	Range	Factory setting
C0	Reset	The set points in the user menu are reset. The more advanced settings can be reset only from the installer menu. The information as number of hours of the compressor and fan cannot be reset.	OFF/ON	OFF
C1	Info	The software version is displayed.	-	-
C2	Time	The time can be adjusted here.	-	-
C3	Date	The date can be adjusted here.	-	-
C4	Day	The day of the week can be selected.	-	Monday
C5	Language	More languages can be selected.	-	English
C6	Contrast	The contrast of the screen can be adjusted.	-	-

7.4.4. Installer menu

The installer menu should only be accessed by qualified personnel. Some of the set points that can be regulated from this menu can have large effects on the unit performance depending on the type of commissioning and installation. There should be a proper match between installer set points and type of installation in order to optimize the performance and lifetime of the unit.

In order to access the Installer Menu, a 4-digits password needs to be entered. The password is: 2016. All temperatures are expressed in °C.

Code	Set point name	Description	Range	Factory setting	
D0	Reset all	All the set points are reset to original factory settings. The Information menu and the installer set points are also modified.	OFF/ON	OFF	
D1	Errors	The alarms of the unit can be checked here.	-	-	
D2	Modbus	D2.0 Address	Modbus address. The Modbus address can be selected between 1 and 247.	1-247	30
		D2.1 Baud Rate	Modbus baud rate. The modbus baud rate can be selected between 19200 and 9600.	9600 - 19200	19200
		D2.2 Parity	Modbus parity. The modbus parity can be set to Even, Odd or deactivated.	Even/ Odd/ None	Even
		D2.3 Modify	Modbus modify. If this function is activated, it is possible to modify the set points kept for development with a data logger.	OFF/ON	OFF
D3	Source flow max	The maximum flow of the heat source can be regulated.	0-100	80	
D4	Source flow min	The minimum flow of the heat source can be regulated.	0-100	40	
D5	DELTA T Source	The heat source temperature difference between inlet and outlet can be adjusted. If B1 (Flow Control) is in AUTO this set point allows for further adjustment of the AUTO heat source temperature difference described in Figure 19. If B1 (Flow Control) is in FIXED this set point determines the desired heat source temperature difference.	-20 - 20	0	
D6	Return T	This set point allows to regulate the desired heat source outlet temperature if B1 (Flow Control) is in RETURN T.	-20 - 50	25	

Code	Set point name	Description	Range	Factory setting
D7	Source T min	The minimum heat source temperature allowed during the operation of the heat pump can be regulated here. If inlet heat source temperature T1 is below D7 Source T min, the heat pump stops and the electric heater runs until the water set point is reached.	0 - 30	10
D8	Source T max	The maximum heat source temperature allowed during the operation of the heat pump can be regulated here. If inlet heat source temperature T1 is above D8 Source T max, the heat pump stops and the electric heater runs until the water set point is reached.	20-89	55
D9	Water T max	The maximum allowed temperature in the tank.	50-70	65
D10	Evaporator T max	The maximum heat source outlet temperature T2 allowed during the operation of the heat pump can be set. If T2 is higher than the set point, then the heat pump stops and electric heater is activated.	20-60	45
D11	Evaporator T min	The minimum evaporator temperature that can be reached by the heat pump.	-10 - 20	4
D12	BACK-UP T	The tank water temperature T3 at which the unit stops the electric heater in BACKUP mode.	5-65	35
D13	Legionella	The legionella function can be activated. The legionella function does not switch the heat pump on, but just continues the heat up cycle to a higher temperature D14 (Legionella T). The legionella operation works only with the heat pump until D28 (T HP MAX). The remaining temperature lift is accomplished with the electric heater alone.	OFF/ON	OFF
D14	Legionella T	The legionella temperature set point can be regulated.	55-65	60
D15	Legionella day	The legionella week day can be set	Monday/ Sunday	Sunday

Code	Set point name	Description	Range	Factory setting
D16	Forced operation	The forced operation of the heat pump can be activated here. The heat pump starts even if there is not need for hot water. When the maximum temperature allowed by the heat pump is reached the unit will stop. This function is to use for testing purposes.	OFF/ON	OFF
D17	Low Tariff weekday	The start and stop time of the low electricity tariff period for weekdays. Three periods can be selected.	0-23 0-23 0-23	00-00 00-00 00-00
D18	Low Tariff weekend	The start and stop time of the low electricity tariff period for weekends. Three periods can be selected.	0-23 0-23 0-23	00-00 00-00 00-00
D19	Light Saving Time	Light Saving Time can be deactivated.	OFF/ON	ON
D20	PV min Voltage HP*	The minimum voltage (V) required in GC1 (PV 0-10V) to start the heat pump when the PV function is active.	0-10	0
D21	PV min Voltage EL*	The minimum voltage (V) required in GC1 (PV 0-10V) to start the electric heater when the PV function is active.	0-10	0
D22	PV min time*	The minimum time (minutes) at which the input voltage (V) from the PV panel should be above the set point D20/D21 (PV min Voltage HP/EL) in order to start the electric heater or heat pump when the PV function is active. D22 also regulates the minimum heat pump operational time when started by the PV function.	0-99	15

Code	Set point name	Description	Range	Factory setting
D23	SG Ready	The SG ready function can be activated by the installer here. Three possible modes can be selected. This function allows the start of the heat pump from an external access. SG ready is not active if there is not external input (SG1 OFF, SG2 OFF).	OFF/ SG Boost/ SG Eco/ SG Block	OFF
	SG BOOST	The heat pump and electric heater must start, if below the max water temperature allowed in the tank. Both Heat Pump and Electric heater are forced to operate (SG1 ON and SG2 ON).		
	SG ECO	The heat pump operates minimizing costs, only the heat pump is activated (SG1 OFF, SG2 ON).		
	SG BLOCK	The unit can be stopped even if there is a need for hot water (SG1 ON, SG2 OFF).		
D24	Start/stop	External control. If GC1 receives a signal higher than 2V, the unit operation is stopped.	OFF/ Start/ stop	OFF
D25	Service timer	The service timer is activated (ON) or deactivated (OFF).	OFF/ON	OFF
D26	Service timer time	If the filter function is ON then the timer of the filter can be selected. This set point determines the number of months after which the filter alarm is displayed.	0-36	12
D27	Service reset	Once the service has been completed, activate this function to reset the filter timer.	OFF/ON	OFF
D28	T HP max	The maximum water temperature that can be reached by the heat pump in °C .	55-70	65
D30	Demo mode	On the display everything looks in operation as conventional mode, but all relays are off and all errors are suppressed. This function can be activated for demonstration purposes.	OFF/ON	OFF
D31	Preheat hysteresis	The temperature difference between the water tank temperature T3 and the heat source inlet temperature T1 at which Preheat operation stops.	-20 - 20	5

Code	Set point name	Description	Range	Factory setting
D32	Preheat (coil)	The Preheat operation can be activated here. In Preheat operation, the water in the tank can be directly heated by the heat source through the coil, without the use of the heat pump.	OFF/ON	-
D33	Interim (coil + HP)	The Interim operation can be activated here. In interim operation, the water in the tank can be heated simultaneously directly by the heat source through the coil and by the heat pump operation. This function allows for the minimization of the electricity consumption.	OFF/ON	-
D34	Pump/valve	Depending on the model of the unit, the operation with a pump or modulating valve can be selected. In units equipped with a pump this set point must not be set as "OFF" and vice versa.	OFF/ON	-
D35	Water hysteresis	The tank water temperature hysteresis can be adjusted.	1-20	-
D36	Brine	If the Brine function is activated, the unit can operate with heat source inlet temperatures of minimum 5C.	OFF/ON	OFF

7.5. Photovoltaic Function

The domestic hot water heat pump (DHWHP) can be controlled by a signal from a solar photovoltaic (PV) converter or an energy meter, either as simple start/stop via a potential free contact or by a variable signal.

Figure 20 represents possible installation configurations with or without energy meter.

Using the variable signal option, a certain output (DC or mA) from the (PV) inverter or the energy meter corresponds to a given amount of excess power for use in the DHWHP. This excess power can be used to activate either the electrical immersion heater, the heat pump (HP) or both.

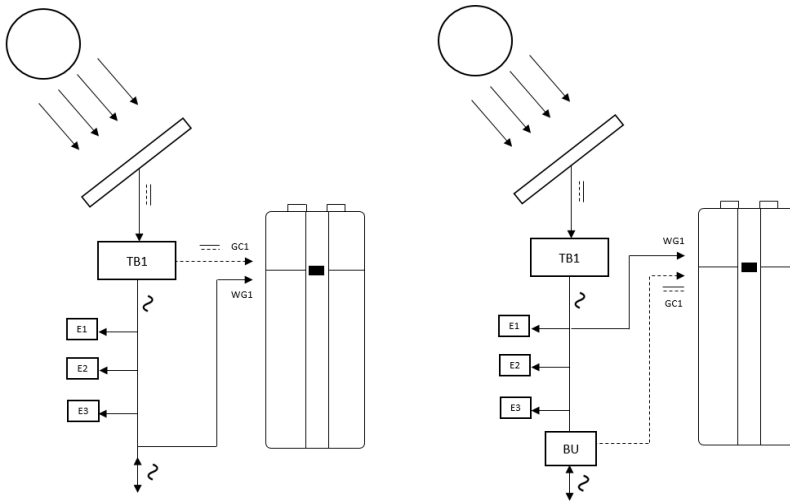

Figure 20 - PV installation 1: control signal from inverter. PV installation 2: control signal from energy meter.

TB1: DC/AC Inverter

BU: Energy meter

E1-2-3: Electric loads

WG1: Heat pump power supply

GC1: Photovoltaic function input signal (0-10 VDC , 0-3 VDC , 4-20 mA).

7.6. Safety features

7.6.1. High pressure switch

In order to ensure that the compressor does not run beyond its operating envelope there is a built-in high pressure switch which shuts down the compressor when the pressure in the refrigerant circuit becomes too high. The pressure switch shuts down the compressor if the pressure gets higher than 25 bar.

To restart the unit, the power must be switched off and switched on again.

7.6.2. Safety breakers

In the event of a failure on the electrical immersion heater, the safety breakers will shut down the unit. If the set value (80°C) is exceeded, the electrical immersion heater will disconnect. The electrical immersion heater can be reactivated when the temperature is below 80°C.

To do this, the power to the unit must be switched off and the front panel dismantled. Then the reset buttons in the center of the breakers can be pressed. This must only be performed by skilled personnel.

Moreover, an additional thermal safety breaker switches off the compressor in case the compressor surface reaches temperatures above 160°C.

8. MAINTENANCE

Please observe local rules and regulations regarding potential periodic inspection of the heat pump by skilled personnel.

8.1. Environmental requirements

When repairing or dismantling the Microbooster Domestic Hot Water Heat Pump please follow the environmental regulations and legal requirements in relation to recycling and disposal of materials.

8.2. Filters

After the first month of operation the filters HZ2 and HZ3 should be cleaned.

8.3. Water circulation and water tank

8.3.1. Pressure relief valve

Your installer has installed a pressure relief valve near the cold water connection on the domestic hot water tank to protect the water tank against excessive pressures when the domestic water expands during the heating process.

The back pressure valve (check valve), which is installed in front of the pressure relief valve on the cold water pipe, prevents water from the tank flowing back into the cold water pipe. Therefore, the pressure in the water tank rises to the maximum setting of the pressure relief valve and the pressure relief valve opens. The redundant water discharges. If the pressure relief valve did not open, the water tank would burst.

The pressure relief valve must be operated regularly to remove lime deposits and to verify that it is not blocked. It is tested by pressing the lever/turning the handle on the pressure relief valve while checking that water discharges. Damages due to a faulty pressure relief valve are not covered by the warranty.

Please note that water may drip from the discharge pipe of the pressure relief valve due to heating of the water.

8.3.2. Anode

In order to prevent corrosion of the enameled hot water tank, a magnesium anode is installed behind the front panel at the top half of the water tank.

The anode has a life expectancy of approximately 2-5 years depending on the water quality.

It is recommended to inspect the anode every year.

- 1) Disconnect the electrical power supply or pull out the power plug.
- 2) Remove the plastic front cover. This allows access to the anode.
- 3) Disconnect the wire connection between the anode and the tank (figure 21).
- 4) Insert a multimeter (range mA) between the anode and the tank. Anode current > 0.3 mA: Anode is active and ok. Anode current < 0.3 mA: Anode should be checked and possibly be replaced.
- 5) Reconnect the wire connection between the anode and the tank. Close the front cover and switch on the unit.

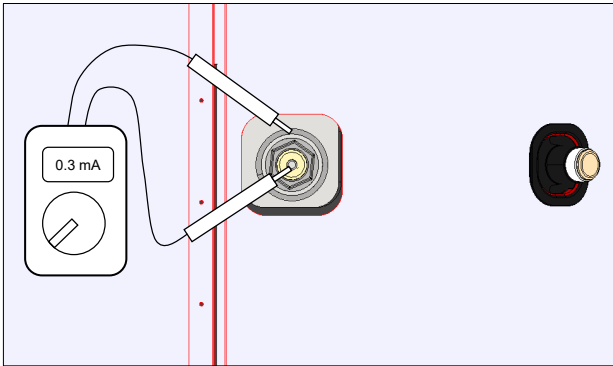

Figure 21 – Anode control

Please note that the water has to be heated to operational temperatures at least once before the test above can be performed.

In order to replace the anode the following should be done:

- Close the cold water inlet.
- Connect a hose to the drain valve so the water from the water tank can run into the nearest drain.
- Open a hot water tapping point (to avoid vacuum in the water tank).
- When the water level in the tank is below the anode, this can be removed for inspection and replacement.

Check and replacement of anode must only be performed by skilled personnel.

9. DISASSEMBLY & DECOMMISSIONING

The following must be done during decommissioning:

- Disconnected the unit from the power mains - i.e. the electrical cables are removed.
- Close the heat source inlet and outlet and drain the fluid out of the source pipes located at the top of the heat pump.
- Close the cold water inlet and attach a hose to the drain valve, so that water from the tank can run to the nearest drain.
- Remove the water and heating pipes.

The unit has to be decommissioned in the most environmentally proper manner. When the product is discarded, please observe the local municipal waste removal regulations.

10. ALARMS AND TROUBLESHOOTING

10.1. Alarms

Alarm	Meaning	Possible reasons	Possible solutions
E1, E2, E3	Temperature sensors out of range	The temperature sensor T1, T2 or T3 is defective or not connected to the PCB	Check that the sensor is connected to the PCB
			Substitute the temperature sensor
E6	High pressure switch	High pressure in the refrigerant system	Reduce the water temperature setpoint
		High pressure switch BP1 is defective or not connected to the PCB	Reduce the maximum heat source flow D3 in the installer menu Substitute component
E7	Low evaporator temperature	Too low heat source flow	Increase minimum heat source flow D4
		Too low heat source temperature	Increase heat source inlet temperature T1
		Air in evaporator	Deaerate evaporator using the air vent
E8	High evaporator temperature	Too high heat source flow	Decrease maximum heat source flow D3
		Too high heat source temperature	Decrease heat source inlet temperature T1
E9	Insufficient heating capacity	Refrigerant leakage	Fix leakages and charge refrigerant (only to be done by authorized technician)
		Wrong position of heat source outlet temperature sensor T2	Check that temperature sensor T2 is positioned on the side of and is in contact with the evaporator
		Wrong position of water temperature sensor T3	Check that temperature sensor T3 is positioned in the temperature pocket
E10	High source inlet temperature	The heat source inlet temperature exceeds D8 (Source T max)	Decrease heat source inlet temperature T1
E11	Service required	The unit requires periodical maintenance	Contact your qualified technician

10.2. Troubleshooting

In addition check out the following questions before contacting an installer:

- Is the cold water supply open?
- Has any of the safety features disengaged the heat pump/electrical emersion heater?
- Has external short-circuiting of terminals disengaged the heat pump?
- Has factory resetting been tested?
- If it is not one of the above errors, please contact: _____

In the warranty period (0-2 years): The installer, from which the unit was purchased.

After the warranty period (> 2 years): The installer from which the unit was purchased or partners of the manufacturer.

Please have data from name plate ready (silver plate on the unit).

Problem	Possible reasons	Possible Solution
The product does not supply hot water	The unit is not connected to the power supply	Make sure the display turns ON
	Alarms from the controller stop the operation of the unit	Check the alarms in the Info menu E
	Low water temperature set points	Increase all temperature set points in menu A Temperatures
	Thermal safety switch opens and stops the power supply to the electric heater	Restore the original conditions of the thermal safety switch
	E7 occurs	Increase D4 (minimum heat source flow) with +10
	SG Ready function is active	Switch OFF SG Ready function
	Thermal safety switch FN1 opens and stops the power supply to the electric heater	Restore the original conditions of the thermal safety switch FN1.
High sound emissions	Components vibration	Make sure all components as compressor and solenoid valve are well fastened

11. WARRANTY

METRO THERM offers a warranty period for all products of 2 years from the documented date of delivery.

For tanks: METRO THERM offers a warranty period of 5 years with respect to internally developed corrosion of the internal tank.

In case of internal corrosion, METRO THERM shall, at its discretion, perform repairs at no charge or redeliver the product.

For heat pumps: METRO THERM offers a warranty period of 2 years with respect to internal malfunctions. In case of an internal malfunction, METRO THERM shall, at its discretion, perform repair at no charge or redeliver the product.

Where repairs are conducted on site, METRO THERM shall deliver new replacement parts, but shall not cover the installation costs

The above shall apply only if the following conditions are met:

- The fitter has contacted METRO THERM prior to the commencement of the repairs or replacement, and an agreement in writing has been reached as to the scope of the repairs.
- The fitter has stated the product's serial number when METRO THERM was contacted.
- The fitter has sent a copy of the purchase invoice or installation invoice as well as the defective product part to METRO THERM within 10 days of the replacement/repair.

The warranty does not cover:

- Regular service and maintenance work.
- Compensation or expenses related to something other than the above noted circumstances or to personal injuries caused by possible defects in the Product.
- Replacement of ordinary wear parts necessitated by natural wear and tear.
- If the Product has been used at a temperature, voltage or pressure different from the specifications on the rating plate.
- If the damage arose from frost, lightning, or dry boiling or is the result of limescale or excess pressure.
- If the Product has undergone repairs or other interventions apart from connection to the mains in accordance with the regulations, and the repair or intervention is the cause of the damage.
- Calcification of the heat exchanger and high-output tank as scale is often a result of

incorrect setup or use of the Product.

- Damage caused by seeping water and concealed water installations.
- Damage caused during transportation. The carrier shall be given notice of such damage.
- Increased or additional expenses related to repairs or replacements conducted during the weekend, on statutory holidays, or outside normal working hours.
- Damage arising from inadequate maintenance or service of the Product. Further for Heat Pumps warranty will only apply if annual statutory service has been performed and can be documented on request.
- If the Product has been positioned in such a way as to impede immediate servicing. Where the Product is difficult to access, METRO THERM disclaims any liability for any extra expenses that may be incurred as a result.
- If the Product is not installed in accordance with the applicable provisions, cf. the instructions for installation and use of the respective Product.

The warranty terms applicable at any time are available at www.metrotherm.dk, as are the management system certificates in accordance with DS/EN ISO 9001, DS/EN ISO 14001 and DS/OHSAS 18001.

12. DECLARATION OF CONFORMITY

The Declaration of Conformity can be downloaded at www.METROTHERM.dk

13. PRODUCT AND INSTALLER INFORMATION

Installed model: _____

Serial number: _____

Accessories: _____

Installers

Pipe installation

Date: _____

Company: _____

Name: _____

Phone number: _____

Electrical installation

Date: _____

Company: _____

Name: _____

Phone number: _____

Commissioning

Date: _____

Company: _____

Name: _____

Phone number: _____

NOTES



METRO THERM A/S
RUNDINSVEJ 55
3200 HELSINGE

INFO@METROTHERM.DK
WWW.METROTHERM.DK