

The eco-friendly heat
pump of the future

METRO Delta



EXPERTS IN HEATING AND HOT WATER



Heating, hot water and passive cooling for smaller homes

METRO Delta is the liquid-to-water heat pump of the future, specially designed for the Nordic region's demanding climate. It can deliver a supply temperature of up to 70°C for domestic heating and hot water using only the heat pump. It does this by utilising the heat from a liquid source, such as thermonet or ground source heating, with temperatures as low as -15°C. In summer, it can also be used to cool your home.

Perfect for smaller homes

The small, wall-mounted heat pump utilises the energy from a liquid heat source to produce heat, hot water and passive cooling for the home. With its 4.7 kW¹⁾ capacity, the heat pump is perfect for smaller homes – terraced houses, flats, etc. However, its small size also makes it ideal for conversions from gas heating in small households, as it is not much larger than the dismantled gas boiler.

Natural refrigerant

The heat pump utilises propane (R290) – a natural refrigerant with a low climate impact. Propane has a very low GWP (Global Warming Potential) of 3, which means that each kg of refrigerant is equivalent to only 3 kg of CO₂. With an impressive SCOP value of 6.2¹⁾, it produces far more energy than it consumes. With a refrigerant charge of only 150 g, it can be installed in existing buildings without any special safety measures.

¹⁾With brine 5°C, heating 35°C.



A flexible heat pump solution

METRO Delta has a wide range of applications and can be combined with two different heat sources: thermonet and ground source. The indoor heat pump solution can also be combined with METRO THERM's range of buffer and heat pump tanks to customize the installation to suit your needs.

Thermonet (shared ground source heating)

Thermonet is a shared energy supply system that typically uses horizontal and vertical ground collectors to supply heat to multiple homes, each with their own liquid-to-water heat pump. Unlike district heating, ground collectors are uninsulated and have no transmission loss to the surroundings.

Ground source heating

Earth is an inexhaustible heat storage – even in sub-zero temperatures. Using ground collectors with brine, METRO Delta can utilise this heat to produce heating and hot water in the home.



Thermonet (shared ground source heating)

- ① METRO Delta
- ② Heat pump tank
- ③ Buffer vessel
- ④ Thermonet (shared ground source heating)
- ⑤ Hot water
- ⑥ Space heating and cooling

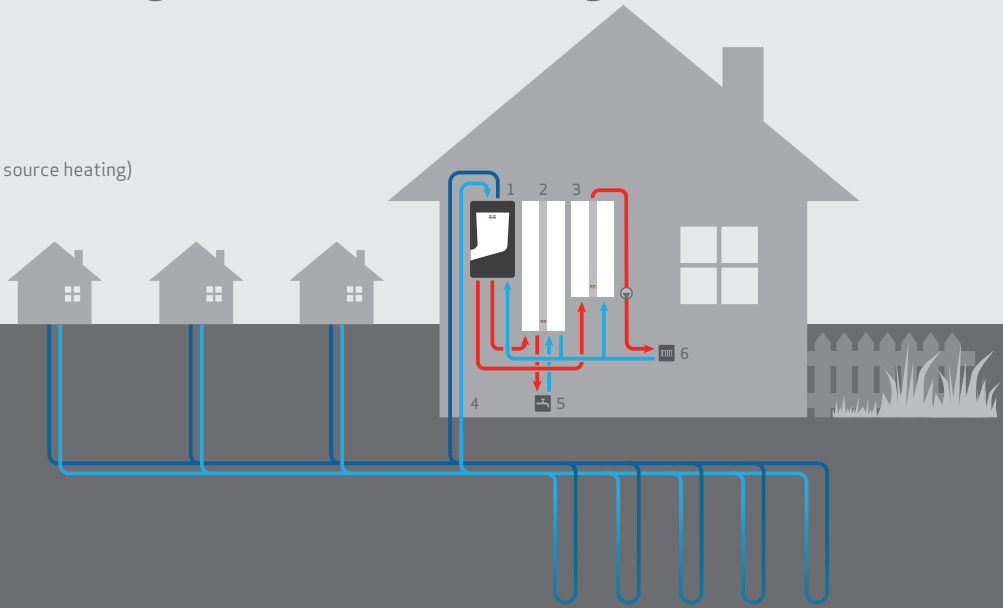

Ground source heating

- ① METRO Delta
- ② Heat pump tank
- ③ Buffer vessel
- ④ Geothermal heating
- ⑤ Hot water
- ⑥ Space heating and cooling

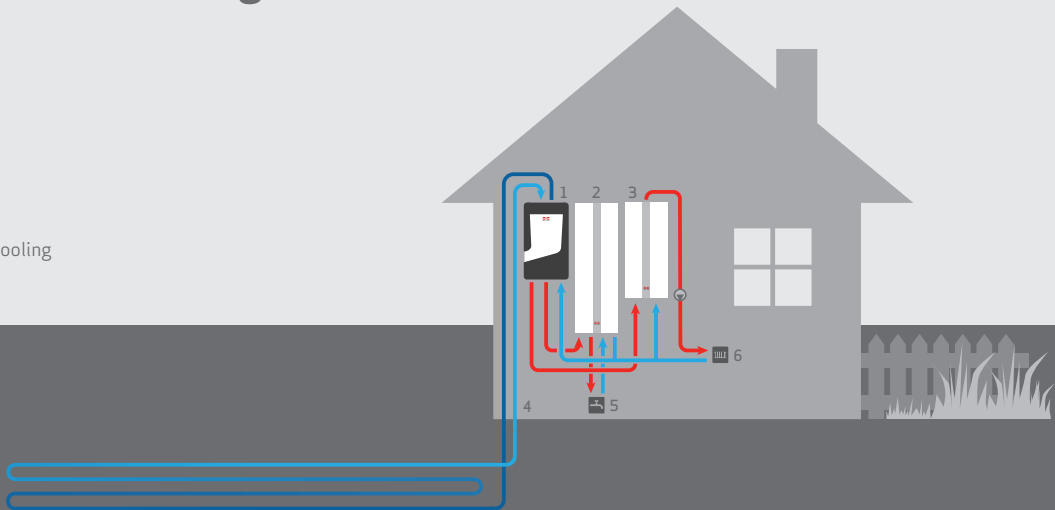

Technical specifications

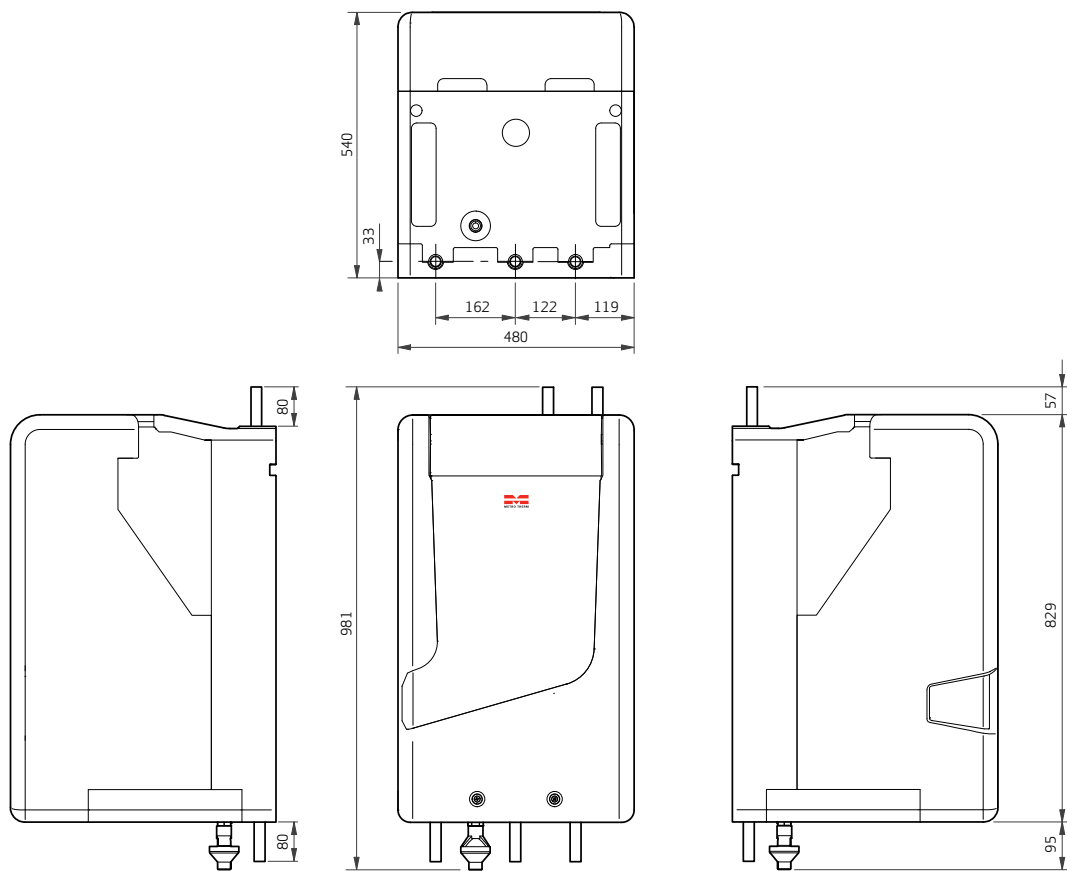

Type		METRO Delta
Product efficiency class, 35/55°C ¹⁾	-	A+++ / A+++
Hot water efficiency class/tap profile ²⁾	-	A+ / L
SCOP _{EN14825} average climate zone, 35/55°C	-	6.2 / 4.7
P _{DESIGN} average climate zone, 35/55°C	kW	4.4 / 3.9
Sound power level (L _{WA}) indoors, 35/55°C	dB(A)	41 / 43
Operating voltage	-	230 V - 50 Hz
Refrigerant charge R290	kg	0.15
CO ₂ equivalent (GWP), hermetically sealed refrigeration circuit	tonnes	0.00045
Dimensions, height/width/depth (incl. pipe connections)	mm	981/480/540
Net weight	kg	56
Pipe connections, primary and secondary side	mm	Ø22

Heating performance data according to EN14511 ³⁾		0/35	0/55	5/35	10/35	10/55
COP	-	4.2	2.9	4.7	5.7	3.7
Heating capacity	[kW]	3	2.6	3.4	4.1	3.6

Cooling performance data according to EN14511 ³⁾		35/18	25/15
COP	-	3.6	5.0
Heating capacity	[kW]	2.8	3.2

¹⁾ Scale for product efficiency class A+++ → D

²⁾ Efficiency class scale, hot water A → G

³⁾ Tested with brine as a heat source

Benefits of METRO Delta

1 Flexible heat pump solution

METRO Delta can be combined with two different eco-friendly heat sources: thermonet and ground source.

2 Silent outdoor installation

No matter which outdoor unit you combine METRO Delta with, the outdoor installation will be completely silent.

3 Natural refrigerant

The heat pump uses a natural refrigerant (propane) with a low climate impact.

4 Ideal as a replacement for gas boilers

The METRO Delta is compact and wall-mounted, making it ideal as a replacement for gas boilers as it does not require floor space.

5 Compact size but high efficiency

METRO Delta has an impressive SCOP value of 6.2¹⁾ and is therefore just as energy efficient as an air-to-water heat pump – even though the size is much more compact.

¹⁾ With brine 5C, heating 35°C.

